

Steps:

- 1) Attach horizontals [1] and [1A] between verticals [2] and [2A], with **infill** placed into inside grooves. See CEI110 Corner Connection instruction on reverse side.
- 2) Attach horizontal [5] between verticals [2A] and [4], sliding **infill** into grooves of verticals, then secure with horizontal [5A]. Make sure Velcro is facing inward and at bottom.
- 3) Attach horizontal [6] between verticals [2] and [3], sliding **infill** into grooves of verticals, then secure with horizontal [6A]. Make sure Velcro is facing inward and at bottom.
- 4) Attach horizontals [7] and [7A] between verticals [3] and [4].
- 5) Connect door to vertical [3]. See **Door Connection** detail.
- 6) Connect **shelf supports** to Velcro on inside of **infills**, then place shelf on top of supports.
- 7) Connect lights and transformer. See **Light Connection** details.
- 8) Install SEG graphic to front of assembled light frame.
See SEG Graphic Installation instruction on general info page.
- 9) Lock counter top to [5A] and [6A]. See **Counter Top Lock** detail.
- 10) Connect power to wireless chargers in Counter Top.

Item	Qty.	Description
1,1A	1,1	22.1654" CEI110 Horizontal Extrusion
2,2A	1,1	38" CEI110 Vertical Extrusion w/ S10
3	1	38" S44 Vertical Extrusion w/ Door Hinges
4	1	38" S44 Vertical Extrusion w/ Door Stop
5,5A	1,1	16" Z45 Horizontal Extrusion
6,6A	1,1	16" Z45 Horizontal Extrusion
7,7A	1,1	18.5" Z45 Horizontal Extrusion

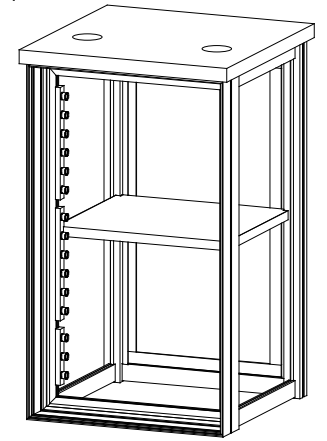

Completed Assembly
(infills not shown)

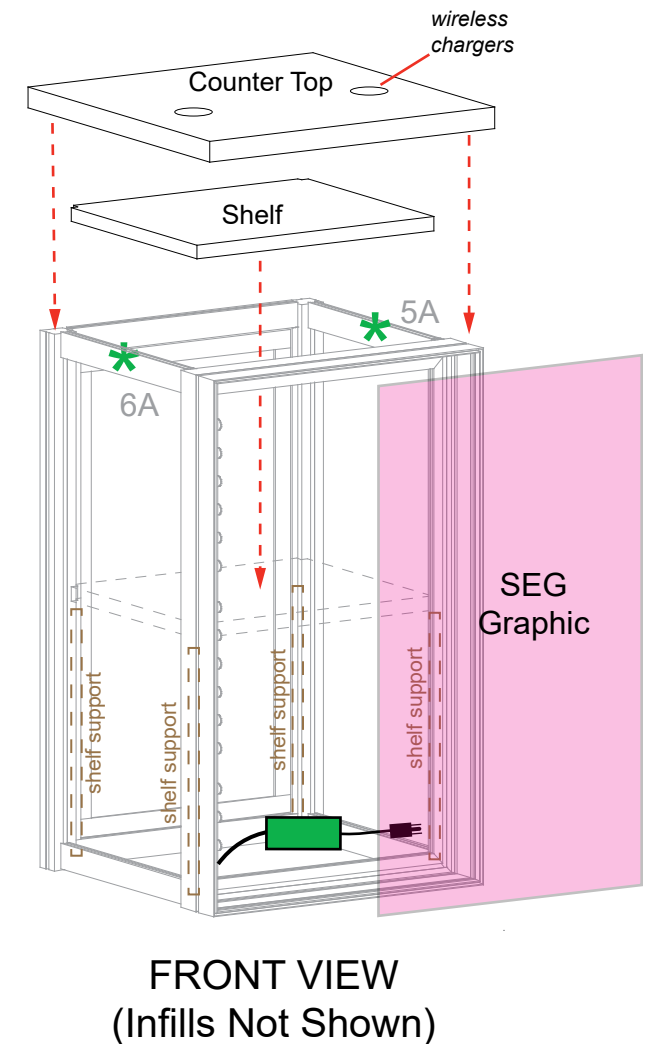
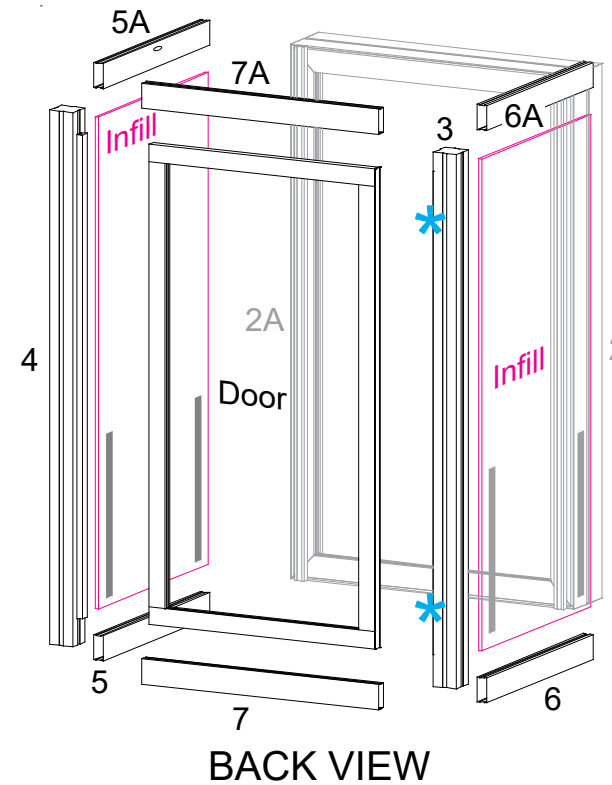
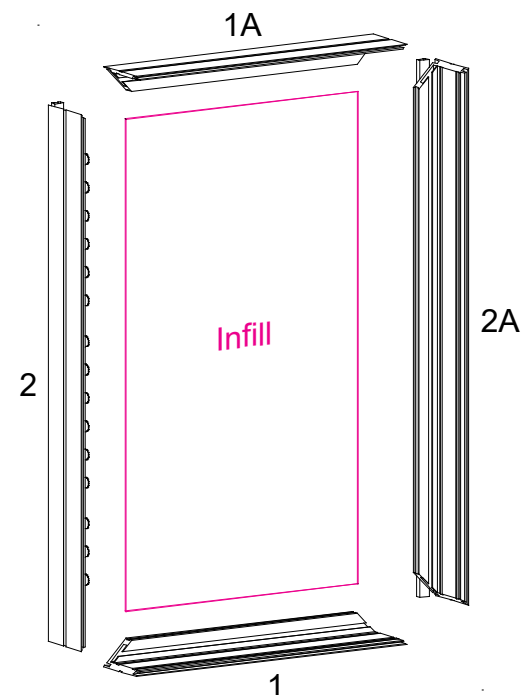
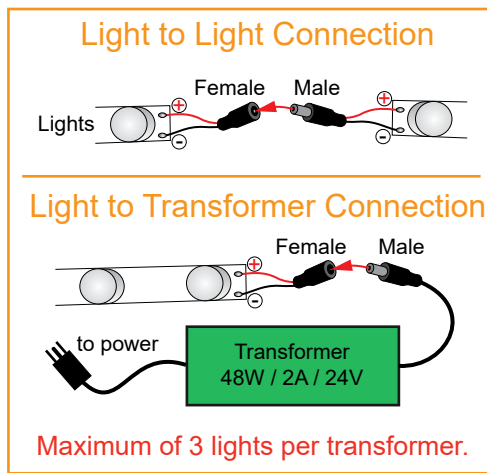
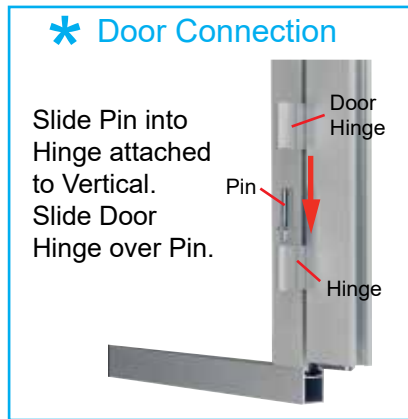
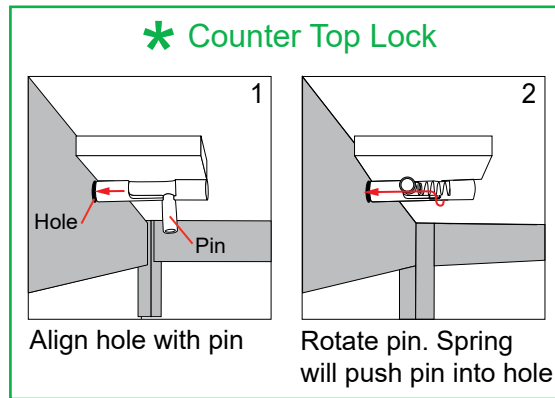

SETUP INSTRUCTIONS

Corner Connection:

- 1) Loosen knobs, then slide vertical extrusions onto **corner connectors** of **lower** horizontal extrusion.
- 2) Slide **corner connectors** of **upper** horizontal extrusion into grooves of vertical extrusions.
- 3) Tighten all knobs to secure connection.

Disassembly:

- 1) Loosen knobs on vertical extrusions.
- 2) Slide the vertical extrusions off of **corner connectors** on lower and upper horizontal extrusions.

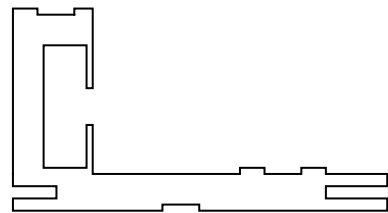

CEI110 Profile

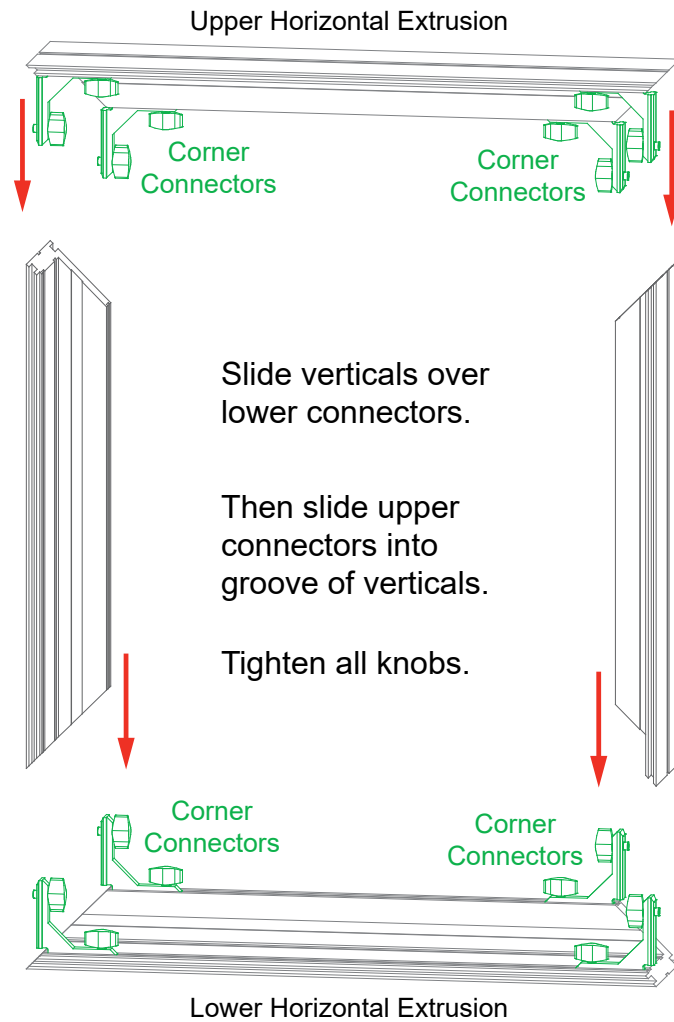

Adjust connectors if necessary to prevent gaps in connection.



COMPLETED ASSEMBLY

Cleaning & Packing:

- For Cleaning Parts, use a **MILD NON-ABRASIVE** cleanser and soft cloth or paper towel.
- Keep exhibit components away from heat and prolonged sun exposure. **Heat and UV exposure will warp and fade components.**
- Retain all provided packing materials. All provided packing materials are for ease of repacking and component protection.

Disassembly:

- For loss prevention, tighten all set screws and locks during disassembly.

SEG Graphic Installation:

- 1) Locate channels along the edges of extrusions
- 2) Insert graphic corners first into channels, then center point of graphic into channels. Allows for proportional fit around the perimeter of the extrusion.
- 3) Working from center to corner, slide silicon edge on graphic into channel.
- 4) After all edges of graphic have been inserted into channels, step back and assess graphic fit. Make adjustments where needed.

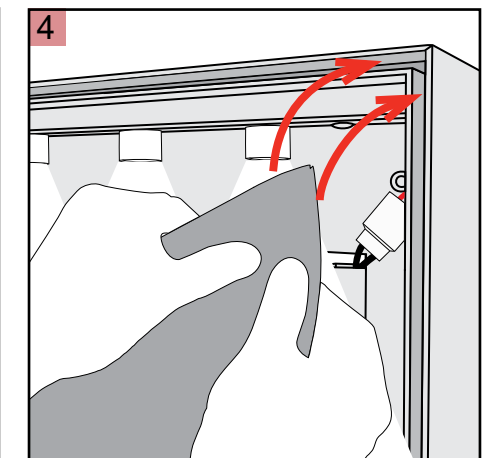
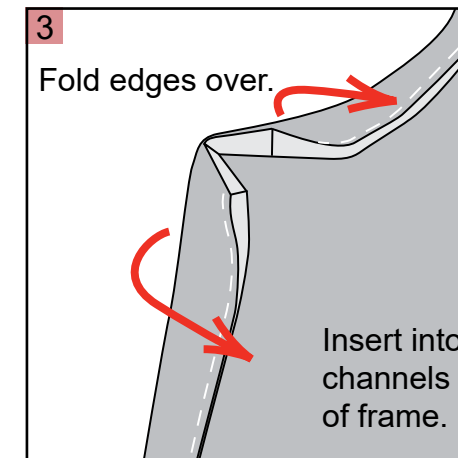
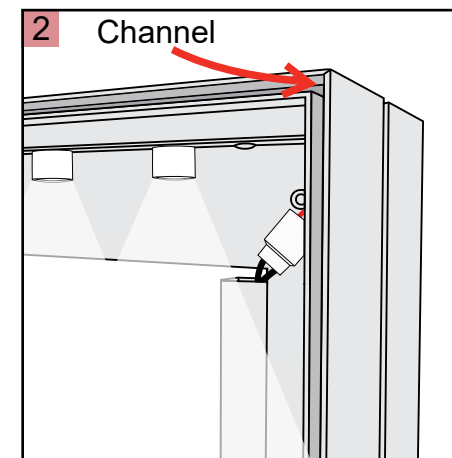
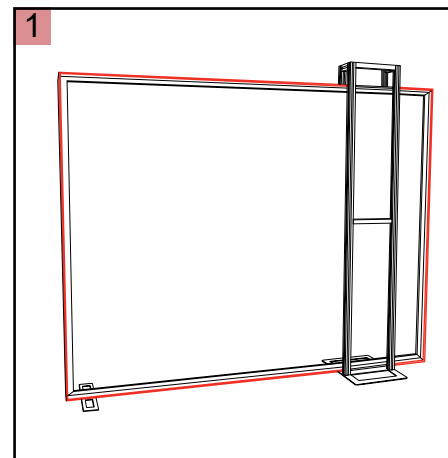

Top View of Each Level

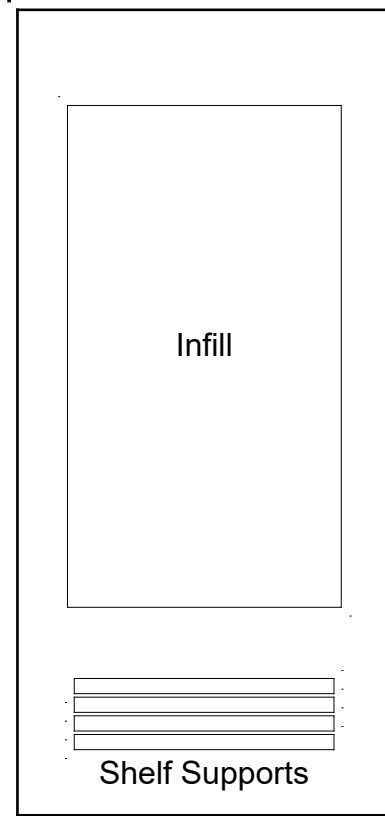

Level 1 (Bottom Level)

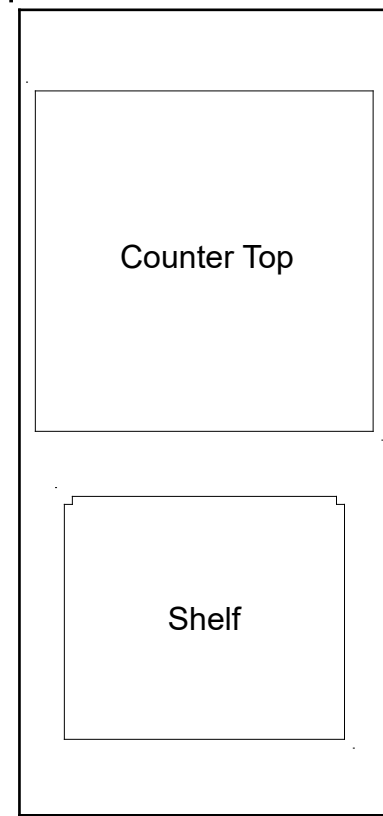

Level 2

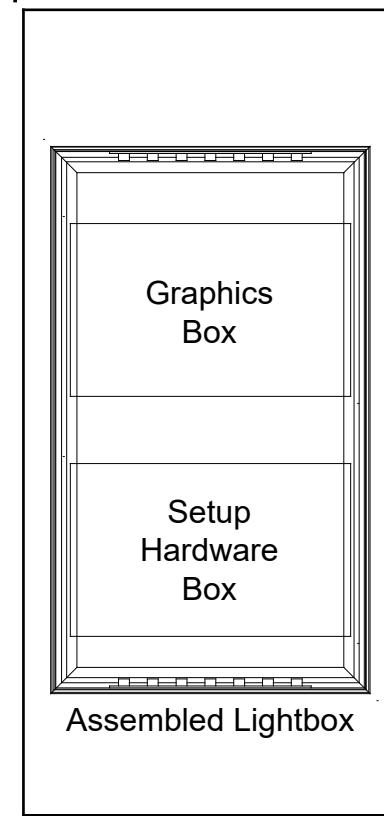

Level 3

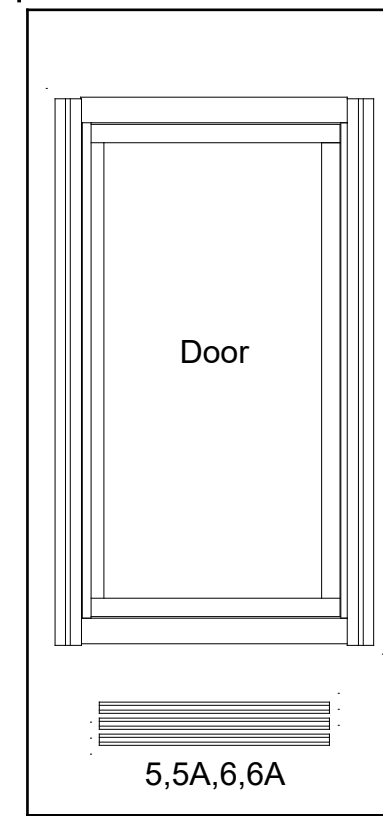

Level 4